

Inclination sensor on MEMS technology

Interfaces: **CANopen** and **Analogue**

Models **NBN65** and **NBA65**

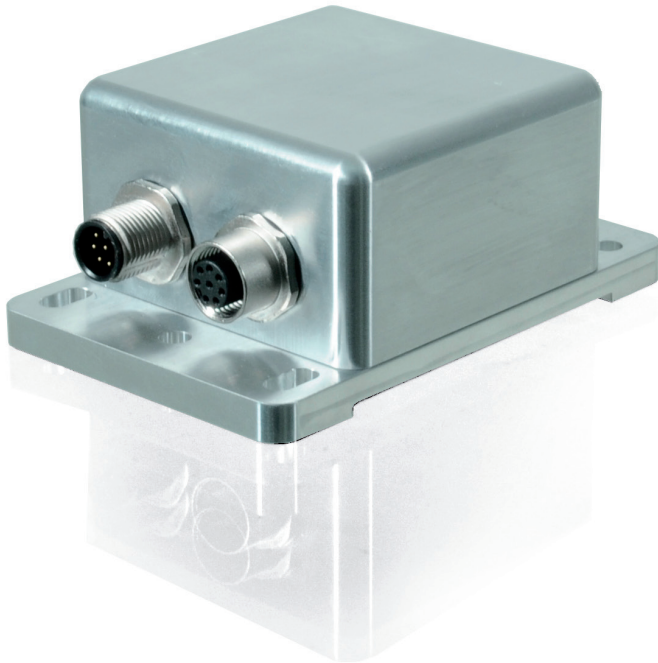

- **Number of measuring axes: 1 or 2**
- **Selectable Measuring range: $\pm 5^\circ$ to $\pm 90^\circ$**
- **Programmable**
- **High vibration and shock resistance**
- **Options:**
 - ◆ **SIL2 certificate:**
see datasheet **NBN 12054**
 - ◆ **Output of acceleration ***
(Special version **NVA65...Bxx**)

Contents

Design and function.....	1
General technical data.....	2
Deliverable accuracies.....	2
Important informations.....	3
CANopen data.....	3
Data format CANopen.....	3
Principle circuit diagram NBN 65.....	4
Characteristic curve.....	5
Programming parameters.....	5
Order code format NBN 65.....	6
Technical data, analogue.....	7
Characteristic curve.....	7
Setting option via multifunctional pins MFP.....	8
Principle circuit diagram NBA 65.....	8
Order code format NBA 65.....	10
Electrical connections.....	11
Accessories.....	11
Installation drawing.....	12
Installation positions and measurement axis assignment.....	13
Further examples for installation positions.....	14
Ordering aids.....	14

Design and function

Registration of inclination in the gravitation field using MEMS sensors (Micro-Electro-Mechanical-System) with subsequent digitisation and linearisation via a controller. Data output is carried out via the CANopen interface or as an analogue signal.

The inclination sensor has a stable aluminium housing (optionally stainless steel). Slots are available for mechanical alignment (up to approx. $\pm 7.5^\circ$). In the case of CANopen, one connector or one male/female connector combination can be selected optionally for connection purposes. Casting measures in the housing lead to the achievement of protection class IP 69K, e.g. for use under water.

MEMS sensors are integrated circuits manufactured using silicon bulk micromechanical technology. These micromechanical structures are used to form dual capacities. If these structures are deflected in the case of acceleration, e.g. gravitational acceleration (**g**), this results in capacity changes, which are registered and further processed using measuring technology. Due to the differential capacity dependency described here, the output voltage follows the function $U \propto g * \sin \alpha$. In this case, the angle α is the inclination angle of the sensor measured against the **g** vector. These sensors measure precisely, have a long service life and are very robust. The measuring axes operate independently of each other.

* : The special version NVA65...Bxx, based on model **NBN65** provides accelerations in 3 axes - not converted into an inclination. Frequency range 0 to 60 Hz, 3 axes. xx means special versions.

Inclinometers NBN65 and NBA65

General technical data

Electrical data

■ Sensor system:	MEMS acceleration sensor
■ No. measuring axes:	1 or 2
■ Measuring range:	$\pm 5^\circ$ to $\pm 90^\circ$
■ Absolute Accuracy and temperature drift	See below "Deliverable accuracies"
■ Repeatability:	$\pm 0.05^\circ$
■ Zero error:	$\pm 0.5^\circ$
■ Noise:	$\pm 0.05^\circ$
■ Signal path:	Parameterisable
■ Reaction time:	1 s (see remark on page 3)
■ EMC standards:	Interference immunity: EN 61000-6-2 Interference emission: EN 61000-6-4

Environmental data

■ Temperature range:	-40 ... +85 °C
■ Storage temp. range:	-20 ... +60 °C (due to packaging)
■ Resilience	
□ To shock:	500 m/s ² ; 11 ms DIN EN 60068-2-27
□ To vibration:	100 m/s ² ; 10 ... 2000 Hz DIN EN 60068-2-6
■ Protection grade:	IP 67, IP 69K (optional)
■ Weight:	Approx. 0.3 kg (aluminium) Approx. 0.65 kg (stainless steel)

Deliverable accuracies

Please ask TWK for versions 2 und 3

Type 1: (Standard)

- Device with 1 or 2 axes, when measuring angle $\pm 20^\circ$ at maximum:

Accuracy:	$\pm 0,25^\circ$ (cross tilt $\pm 5^\circ$), otherwise $\pm 0,5^\circ$
Drift:	$\pm 0,3^\circ$; range [-10 °C to +60 °C] $\pm 0,5^\circ$; range [-40 °C to +85 °C]

- Device with 1 axis, when measuring angle $\pm 90^\circ$:

Accuracy:	$\pm 0,5^\circ$ (cross tilt $\pm 3^\circ$) $\pm 0,25^\circ$ within 20° (cross tilt $\pm 3^\circ$)
Drift:	$\pm 0,3^\circ$; range [-10 °C to +60 °C] for $\pm 60^\circ$ $\pm 0,4^\circ$; range [-40 °C to +65 °C] for $\pm 90^\circ$ $\pm 0,5^\circ$; range [-40 °C to +85 °C] for $\pm 60^\circ$ $\pm 0,6^\circ$; range [-40 °C to +85 °C] for $\pm 90^\circ$

Type 2:

- Device with 1 or 2 axes. Measuring angle in this case $\pm 15^\circ$ at maximum

Accuracy: $\pm 0,25^\circ$

This accuracy specification includes the following operating conditions:

- Lateral inclination up to and including $\pm 15^\circ$
- An operating temperature range from -10°C to 60°C.

(Accuracy without lateral inclination within a temperature range of +15 °C to +30 °C: approx. 0,15°)

Type 3:

- Device with 1 or 2 axes. Measuring angle is up to $\pm 100^\circ$

Accuracy: $\pm 2^\circ$

This value depends on the measuring angle and the operating conditions.
Detailed accuracy specification on demand.



Important informations

The measured axis is no longer detected in case of an inclination in a second axis (cross-axis inclination) is greater than 30°. Meaning the sensor will go in an over flow stage. This feature is required since measuring accuracy decreases with increasing cross-axis inclination.

Behaviour of the due to averaging:

Dynamic, arithmetic averaging of the measured values is implemented in the inclinometer. This involves linear averaging over 1000 values, whereby a new value is recorded every millisecond. This results in a low-pass effect. In the event of an abrupt change in the measuring angle, the end value is reached after approx. 1 second. In the event of a linear change in the measuring angle, the relevant output signal follows after a delay of approx. 0.6 seconds. Other, e.g. shorter, values may be set depending on application conditions. However, the output signal then tends to have a higher noise factor.

CANopen data

Function

A CAN controller at the output enables integration into the CANopen network. The protocol is designed according to "CAN-open Application Layer and Communication Profile, CiA Draft Standard 301, version 4.1" as well as according to "Device Profile for Inclinometers, CiA Draft Standard Proposal 410, version 1.2" and "CANopen Layer Setting Services and Protocol (LSS), CiA DSP 305, version 1.1.1". The sensor is also available with a redundant system and CANopen safety profile (see datasheet NXN 12054).

- Operating voltage: 11 to 36 VDC
- Resolution: 0.01°
- Power consumption: < 1 W
- Signal path: Ascending values with CCW (parameterisable)
- Measuring range: ± 5° to ± 90°
- Output code: Binary
- Transmission rate: 1 MBaud
- CAN interface: According to ISO/DIS 11898
- Address/baud rate setting: Via SDO/LSS
- Terminating resistor: To be implemented separately
- Max. transmission length: 200 m *

The design guideline "CiA Draft Recommendation 303 CANopen additional specification Part 1: Cabling and connector pin assignment" must be observed on installation.

* No galvanic separation between supply voltage and bus lines (also see CiA DS301).

CANopen features

- NMT master: No
- NMT slave: Yes
- Maximum boot-up: No
- Minimum boot-up: Yes
- COB ID distribution: Default, SDO
- Node ID distribution: Via Index 2000 or LSS
- No. of PDOs: 2 Tx
- PDO modes: Sync, async, cyclic, acyclic
- Variable PDO mapping: No
- Emergency message: Yes
- Heartbeat: Yes
- No. of SDOs: 1 Rx / 1 Tx
- Device profile: CiA DSP 410 Version 1.2
- Baudrate, factory setting: 20 kBaud
- Node ID, factory setting: 1

A detailed description of the profile you will find in the NBN 12527 specification.

Data format CANopen (Model NBN65: Inclination values. Model NVA65...Bxx (based on NBN65): Acceleration values)

Data Byte 0		Data Byte 1		Data Byte 2		Data Byte 3		Data Byte 4		Data Byte 5																																					
0	1	2	3	4	5	6	7	8	9	10	11	12	13	14	15	16	17	18	19	20	21	22	23	24	25	26	27	28	29	30	31	32	33	34	35	36	37	38	39	40	41	42	43	44	45	46	47
LSB				MSB				LSB				MSB				LSB				MSB																											
Angle (Acceleration) x-axis						Angle (Acceleration) y-axis						Angle (Acceleration) z-axis																																			

Inclinometers NBN65

CANopen data

Bus activation according to ISO / DIS 11898

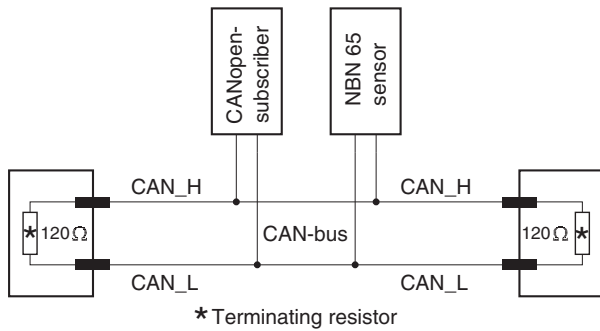

Principle circuit diagram NBN 65

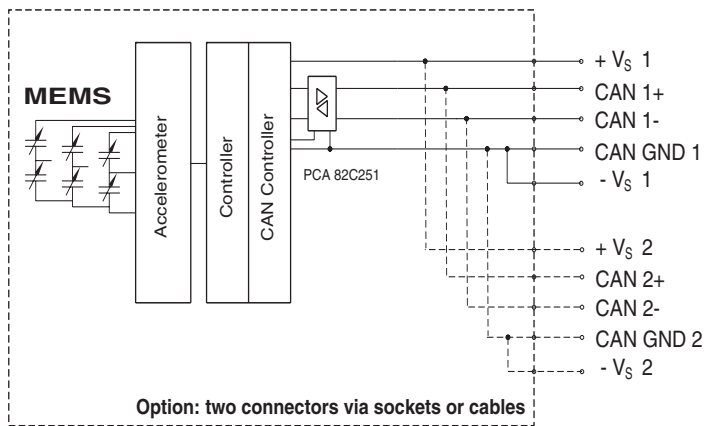

Output level according to ISO/DIS 11898

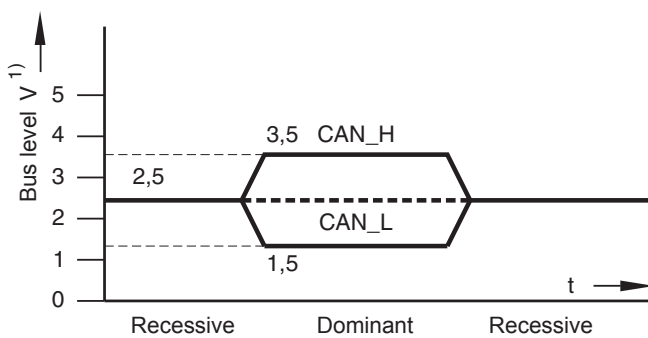

Inclinometers NBN65

CANopen data

Characteristic curve

- Example: $\pm 70^\circ \triangleq 2 \times 7000$ increments with resolution 0.01° .
- Data format: Signed 16-bit.

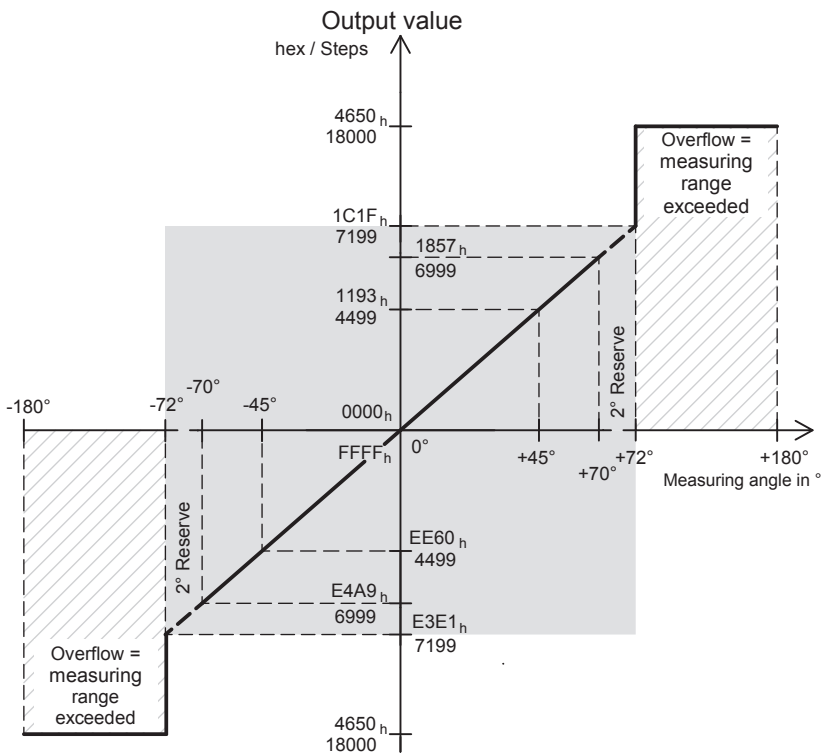

When exceeding the selected range (eg $\pm 70^\circ$), plus about 2° the CANopen output values is set to 4650hex (= 18,000 steps = 180°) in order to signal the controller that the inclinometer is tilted out of the selected scale.

Special version NVA65...Bxx, based on model NBN65, provides 4096 digits/g resolution as a signed 16 Bit output value for positive and negative accelerations due to forward and backward acceleration direction.

Programming parameters

Parameter	Function
Resolution	$0,1^\circ / 0.01^\circ$
Zeroing / preset value	Adjustment within $\pm 5^\circ$
Signal path	CW / CCW
Scaling	On / Off

Documentation, EDS file, etc.

- The following documents plus the EDS file, a bitmap and example programmes can be found in the Internet under www.twk.de in the documentation section, model NBN (letter "N")

- Data sheet No. NBX 11918
- Specification No. NBN 12527

Optionally, a CD-ROM can be supplied.
(Article No. TWK-CD-01; please specify when ordering.)

- Supply source for the listed CANopen specifications:
CAN in Automation (CiA),
Kontumazgarten 3,
D-90429 Nuremberg
(Email: headquarters@can-cia.org, www.can-cia.org)

Inclinometers NBN65

Order code format NBN 65

Please enter installation position "TOP 1...6" into the order number. See page 13 and 14 for a description.

NBN	65	-	A	x / y / z	C3	-	1	-	S	1	N	01
<p>Electrical and mechanical variants *</p> <p>01 Standard</p> <p>50 Connection via plug M12, 5 pins instead 8</p> <p>Output interface:</p> <p>N CANopen</p> <p>Electrical connections:</p> <p>1 Single connection</p> <p>2 Double connection</p> <p>Electrical connections ***:</p> <p>S Device connector M12</p> <p>K Cable 1 m</p> <p>Installation position:</p> <p>1 TOP 1, 2, 3, 4, 5, 6 (See pages 13-14)</p> <p>Profiles:</p> <p>C2 CANopen according to CiA, DS 301 Version 4.1, DS 410 Version 1.2</p> <p>Measuring ranges **: Please assign the measuring angles which you require to the "x, y, z" axes</p> <p>± z° z-axis Two axes at maximum selectable (Selectable from ± 5° to ± 90° in 5° steps)</p> <p>± y° y-axis For the undesired axis please choose '0' (Explanation on page 13 -14)</p> <p>± x° x-axis</p> <p>Housing material ***:</p> <p>A Aluminium AlMgSi1</p> <p>S Stainless steel 1.4305 (option 1.4404)</p> <p>Design form:</p> <p>65 65 mm</p>												
<p>NBN with CANopen interface</p>												

- * The basic versions according to the data sheet bear the number 01. Deviations are identified with a variant number and are documented in the factory. NBN: variant 50 is firmly assigned: electrical connection via M12, 5-pin (instead of 8-pin).
- ** The measuring ranges for the various measurement axes can be selected in 5° steps, whereby it must be noted that only 2 axes can be used at any one time. Accuracy differences may possibly arise in terms of the compatibility of the measuring ranges or the measuring angles. If in doubt, please talk to one of our employees.
- *** Aluminium housing with connector M12, stainless steel housing preferably with cable 1 m and D-sub connector without cap (for test purposes).
- **** The special version NVA65...Bxx, based on model **NBN65**, provides acceleration output - not converted in an inclination value. Frequency range: 0 to 60 Hz in 3 axes. xx means special versions. This datasheet and CANopen specifications NBN12527 are valid. In all other cases of series NVA65 the regular documentation NVA12634 (Datasheet) and NVA12657 (CANopen specifications) are valid.

The following configurations can be supplied (see order code format)

Profiles

- **CANopen profile C3:** one measuring system with CANopen profile according to CiA, DS 301 version 4.1, DS 410 version 1.2.
- **CANopen safety profile with or without SIL2 certificate:** see separate datasheet NXN12054

Electrical connection

- one connector or one cable
- male/female connector combination or two cables in order to loop the CANopen bus and the voltage supply through.

Inclinometers NBA65

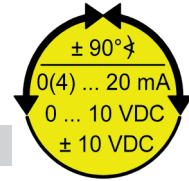

Technical data, analogue

Function

The contactless MEMS sensor system is extended using a 12-bit D/A converter so that the measuring variable is available as an analogue signal from 0 (4) to 20 mA, 0 to 10 VDC or ± 10 VDC.

The customer can adjust the signal path (CW or CCW) and the measuring range from $\pm 5^\circ$ to $\pm 90^\circ$ in 5° steps (i.e. $2,5^\circ$ on each side). Example: from $\pm 5^\circ$ is the next step $\pm 7,5^\circ$. The preset "centre of measuring range" value can be set (see explanations on pages 5 and 7).

Electrical connection is carried out via one male connector M12, 8 pins, A-coded or cables.

On ordering, the measuring ranges must be selected according to the application (from $\pm 5^\circ$ to $\pm 90^\circ$ in 5° steps ($2,5^\circ$ on each side), e.g. $\pm 5^\circ$, $\pm 7.5^\circ$, $\pm 10^\circ$ etc.). If the sensor is inclined past this measuring range, an overflow is output.

Due to the 12-bit D/A converter, the resolution of the output signal is dependent on the selected measuring range.

Examples: At $\pm 90^\circ$, it is 0.05° . At $\pm 20^\circ$, it is 0.01° , etc. (better than 0.01° is not possible).

Electrical data

- Operating voltage: 20 to 30 VDC (output: A,B,C)
- Power consumption: < 1 W
- Current: approx. 40 mA
- Resolution: 0.05° with $\pm 90^\circ$ measuring range (12-bit D/A converter)
(higher resolutions with smaller measuring ranges)
- Measuring range: $\pm 5^\circ$ to $\pm 90^\circ$ (parameterisable)
- D/A converter: 12-bit
- Signal path: Adjustable (CW or CCW)
- Preset value: Centre of measuring range, optionally other values

Electrical output data

- **Current output A:** 0 to 20 mA
- **B:** 4 to 20 mA
- Accuracy: $\pm 50 \mu\text{A}$
- Load resistance (burden): 0 ... 500 Ω
- **Voltage output C:** 0 to 10 VDC
- Accuracy: At 0 V + 100 mV
At 10 V ± 25 mV
- Output current: Max. 5 mA (short-circuit-proof) Corresp. to load resistance ≥ 2 k Ω

Characteristic curve (measuring range $\pm 90^\circ$)

Current output B:

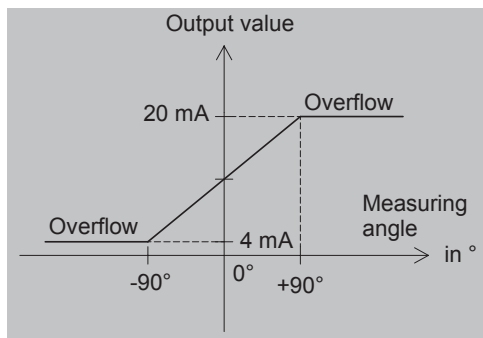

Inclinometers NBA65

Technical data, analogue

Setting option via multifunctional pins MFP

The **signal path**, **preset value** and **measuring range** parameters and the **default values** can be set by the user according to the conditions in the operating location. Three multifunctional inputs are provided for this purpose. The input circuit for the MFPs is E1(see page 9).

The basic factory setting in accordance with the order number (i.e. signal path, original zero point and measuring range) can be restored on activation of the default values.

The signal path determines the inclination direction in which the output signal increases positively (see page 13-14).

The measuring range can be incremented by activating the corresponding MFP(s) in 5° steps (2,5° on each side) up to a maximum of ± 90° (e.g. ± 10° to ± 12.5°), with reference to the measuring axes selected on ordering. On further activation, the measuring range jumps back to the minimum value of ± 5°, etc.

The preset value is set to the centre of the measuring range. Other values can be implemented in the factory.

Table for multifunctional inputs (MFP). The functions for the 2nd axis are omitted in the 1-axis sensor				
Function	MFP 0	MFP 1	MFP 2	Logical 1 $\hat{=}$ 11...+UB, logical 0 $\hat{=}$ < 5 V or open
Signal path (CW / CCW), 1st axis (e.g. x)	1	0	0	Set pin MFP 0 to logical one for the duration of 4 s.
Set preset value, 1st axis	0	1	0	Set pin MFP 1 to logical one for the duration of 4 s.
Increment measuring range by 5° in each case, 1st axis	0	0	1	Set pin MFP 2 to logical one for the duration of 4 s.
Signal path (CW / CCW), 2nd axis (e.g. y)	1	1	0	Simultaneously set pins MFP 0 and MFP 1 to logical one for the duration of 4 s.
Set preset value, 2nd axis	1	0	1	Simultaneously set pins MFP 0 and MFP 2 to logical one for the duration of 4 s.
Increment measuring range by 5° in each case, 2nd axis	0	1	1	Simultaneously set pins MFP 1 and MFP 2 to logical one for the duration of 4 s.
Set default values for all axes	1	1	1	Simultaneously set pins MFP 0, MFP 1 and MFP 2 to logical one for the duration of 4 s.
Normal operation	0	0	0	MFP 0, MFP 1 and MFP 2 to logical 0 or open

Principle circuit diagram NBA 65

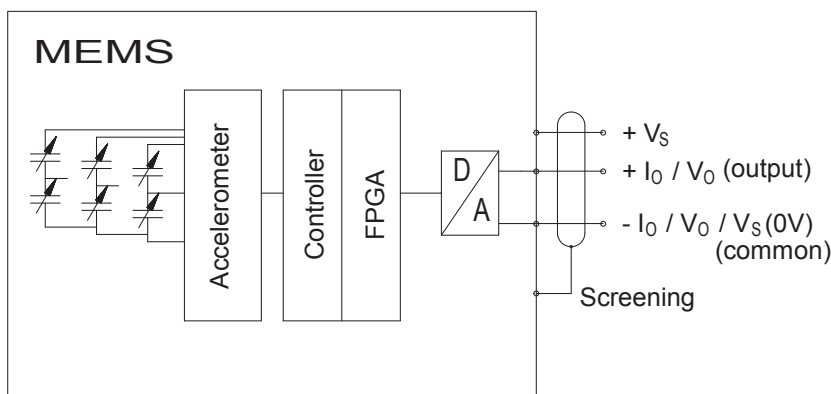

Inclinometers NBA65

Technical data, analogue

Output circuits

Output A

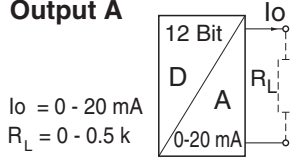

Output B

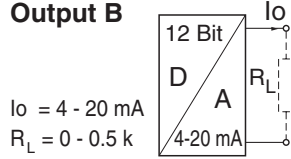

Output C

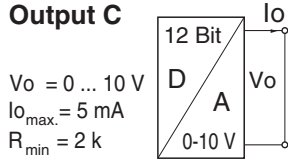

Input circuit E1 for multifunctional pins (MFP)

Input E1 active "high"

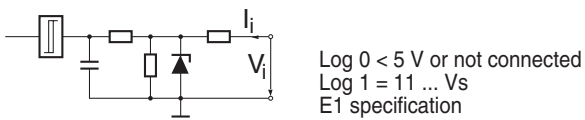

Timing charts for the MFP settings

1. Set MFP 0 or MFP 1 or MFP 2 once

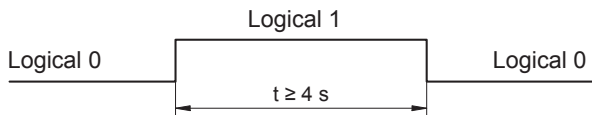

2. Set two or all three MFPs simultaneously

Time difference between MFP 0 and MFP 1 (and MFP 2) ≤ 0.25 s.

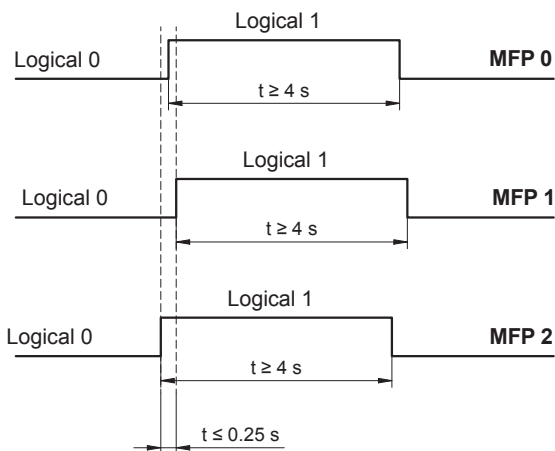

Inclinometer NBA65

Order code format NBA 65

Please enter installation position "TOP 1...6" into the order number. See page 13 and 14 for a description.

NBA	65	-	A	x / y / z	W	S	1	-	2	-	B	01
<p>Electrical and mechanical variants *</p> <p>01 Standard</p> <p>Output signals:</p> <p>A 0 - 20 mA</p> <p>B 4 - 20 mA</p> <p>C 0 - 10 V</p> <p>Installation position:</p> <p>2 TOP 1, 2, 3, 4, 5, 6 (See pages 13-14)</p> <p>Version:</p> <p>1 1 measuring system</p> <p>Electrical connections ***:</p> <p>S Device connector M12</p> <p>K Cable 1 m</p> <p>Signal path:</p> <p>W CW For all measuring ranges. (See explanation on page 13)</p> <p>C CCW</p> <p>Measuring ranges **: $\pm z^\circ$ z-axis Please assign the measuring angles which you require to the "x, y, z" axes $\pm y^\circ$ y-axis Two axes at maximum selectable (Selectable from $\pm 5^\circ$ to $\pm 90^\circ$ in 5° steps) $\pm x^\circ$ x-axis For the undesired axis please choose '0' (Explanation on page 13 -14)</p> <p>Housing material ***:</p> <p>A Aluminium AlMgSi1</p> <p>S Stainless steel 1.4305 (option 1.4404)</p> <p>Design form:</p> <p>65 65 mm</p>												
<p>NBA with analogue interface</p>												

- * The basic versions according to the data sheet bear the number 01. Deviations are identified with a variant number and are documented in the factory.
- ** The measuring ranges for the various measurement axes can be selected in 5° steps ($2,5^\circ$ on each side), whereby it must be noted that only 2 axes can be used at any one time. Accuracy differences may possibly arise in terms of the compatibility of the measuring ranges or the measuring angles. If in doubt, please talk to one of our employees.
- *** Aluminium housing with connector M12, stainless steel housing preferably with cable 1 m and D-sub connector without cap (for test purposes).

Inclinometers NBN65 and NBA65

Electrical connections

- Via:
- 1 connector M12 (male)
 - 2 connectors M12 (male + female), 8-pin in each case
 - 2 connectors M12 (male + female), 5-pin in each case (Variant 50 in CANopen sensor NBN65 order code format)
 - 1 or 2 cables

Electrical connection at the mating connector (View on clamp- or soldering side)

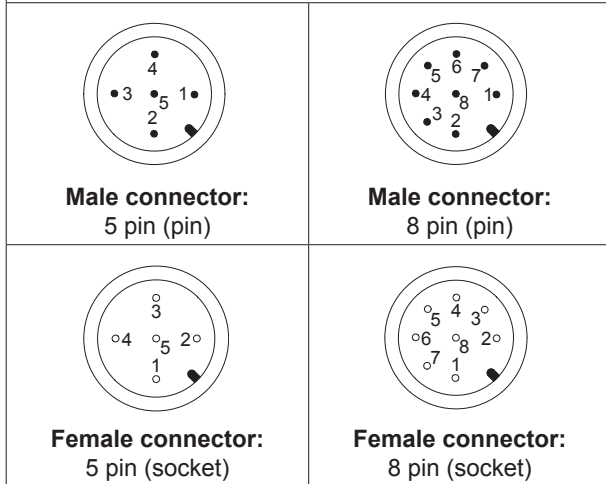

The pin assignment can be found in the connection assignment which is enclosed with each device.

Accessories

- Mating connector (EMC) **STK5GP90** (M12, 5 pin male connector (pin), A-coded)
- Mating connector (EMC) **STK5GS56** (M12, 5 pin female connector (socket), A-coded)
- Mating connector (EMC) **STK8GP99** (M12, 8 pin male connector (pin), A-coded)
- Mating connector (EMC) **STK8GS54** (M12, 8 pin female connector (socket), A-coded)

(Mating connectors have to be ordered separately)

Inclinometers NBN65 and NBA65

Installation drawing

Via round and slotted mounting holes for M5 bolts. The inclination sensor can be mechanically adjusted up to approx. $\pm 7.5^\circ$ via the slots. Fasteners are not enclosed in the scope of delivery.

No dummy plug in case of two connectors.

Dimensions in mm

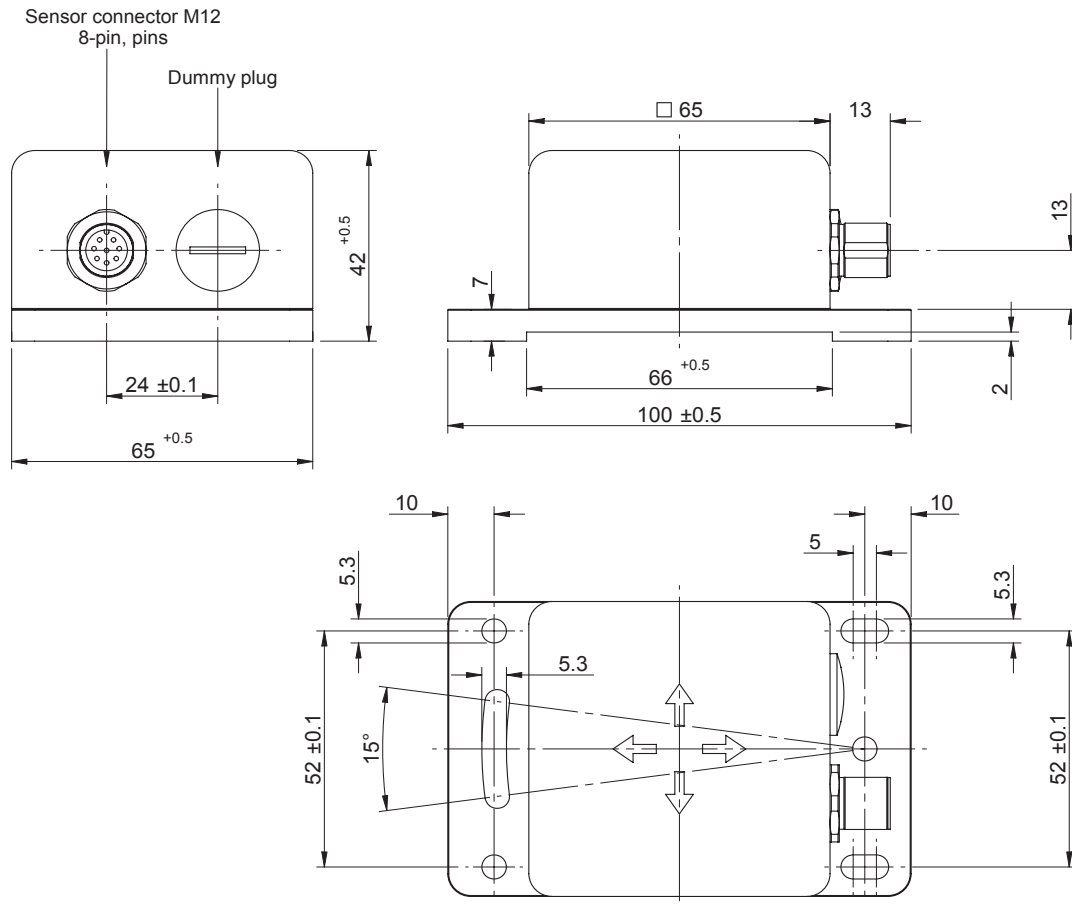

Materials used

- Aluminium housing: AlMgSi1
- Stainless steel housing: 1.4305 (option 1.4404)
- Connector/cable gland: Ms, nickel plated (option stainless steel)
- Sealing rings: NBR

Inclinometers NBN65 and NBA65

Installation positions and measurement axis assignment

Installation position TOP 1... 6 of the 1- or 2-axis inclinometer must be taken into consideration on assignment or selection of the **measurement axes**. The installation positions specified below define the measurement axes and measuring range centre for x, y and z.

Which of housing surfaces 1 to 6 is to point upwards must be specified in the order number for the NBN65 (see figure on the right). The installation position is clearly marked on each device ('TOP'). This surface/edge must point upwards.

Only 2 of 3 axes are selectable. The installation position determines these axes.

Signal path: with the CW setting, the prefixes in the figures below specify the direction of rotation in which the output values increase positively during inclination measurement. This is accordingly reversed with the setting CCW.

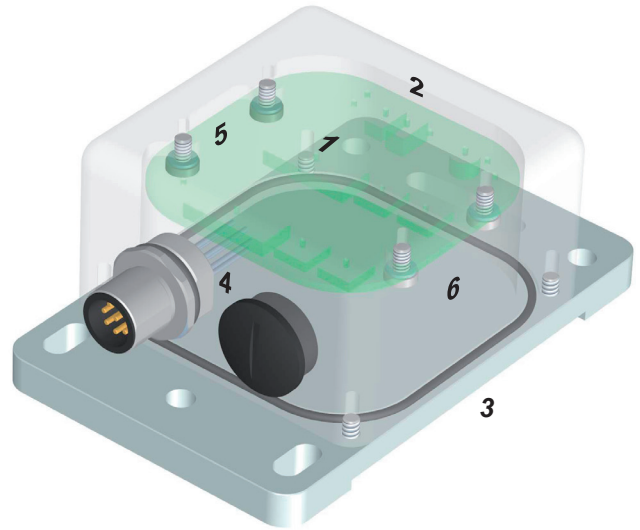

1: Upper side	2: Rear side	3: Lower side
4: Connector side	5: Left side	6: Right side

E.g. NBN 65 - A xx / yy / zz C3 - 1 - S 1 N 50: TOP1

In this example, circumstances necessitate the installation of the inclinometer in installation position "5".

The y axis with a range of $\pm 35^\circ$ to be measured and the z axis with a range of $\pm 12^\circ$ to be measured are required for measurement.

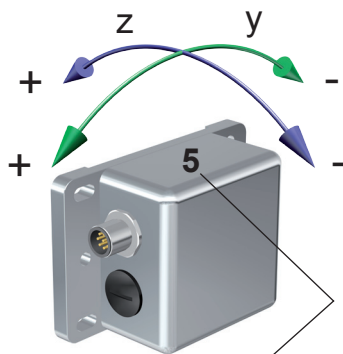

Installation position 5 (with reference to the upper side)

NBN65 - A 0/35/12 C3 - 5 - S 1 N 01

- z-axis = $12^\circ (\pm 12^\circ)$
- y-axis = $35^\circ (\pm 35^\circ)$
- x-axis = 0° (As the x axis is not available in this installation position, it is specified as 0)

Inclinometers NBN65 and NBA65

Further examples for installation positions

Further examples which refer to the assumed example measuring angles.

$x = \pm 90^\circ$ $y = \pm 25^\circ$ $z = \pm 15^\circ$

It is to be noted that the installation position always represents the device surface which is viewed from above. In the various illustrations, this is indicated with the bold number and must be specified on ordering under all circumstances.

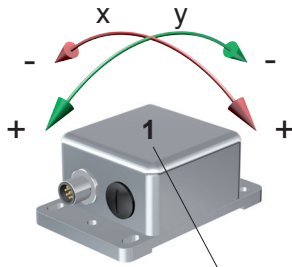

NBN65 - A 90/25/0 C3 - 1 - S 1 N01

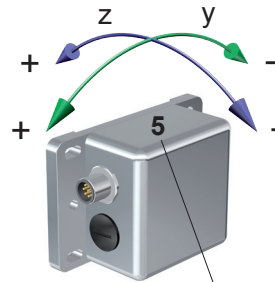

NBN65 - A 0/25/15 C3 - 5 - S 1 N01

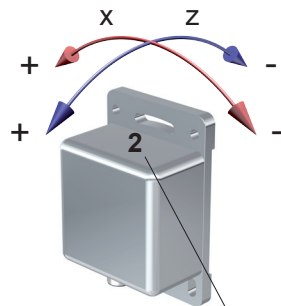

NBN65 - A 90/0/15 C3 - 2 - S 1 N01

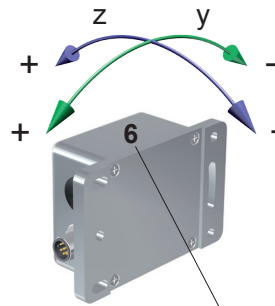

NBN65 - A 0/25/15 C3 - 6 - S 1 N01

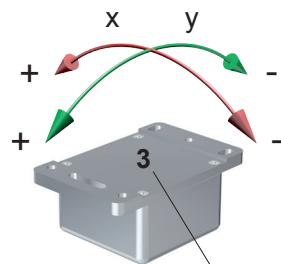

NBN65 - A 90/25/0 C3 - 3 - S 1 N01

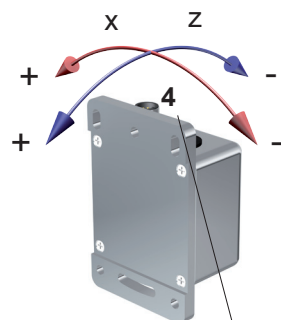

NBN65 - A 90/0/15 C3 - 4 - S 1 N01

Ordering aids

Model NBN65 with CANopen interface

NBN	65	-	°	°	°	C3	-	-	-	N	01
Model	Design form	Housing material	x axis	y axis	z axis	Profile (CANopen)	Installation position	Connector / cable	Connection (single/double)	CANopen	Variant *
			Only two axes can be selected. The undesired axis is specified as 0°.								

Model NBA65 with analogue interface

NBA	65	-	°	°	°			1	-	-	01
Model	Design form	Housing material	x axis	y axis	z axis	Signal path	Connector / cable	Versions	Installation position	Output signal	Variant *
			Only two axes can be selected. The undesired axis is specified as 0°.								

* Variant 01 contains the standard version according to the data sheet. If this version does not meet your wishes, please talk to one of our customer service advisors.